



2013 Airbus EC135P2+ | #1107 | TC-HGA

TOTAL HOURS

2,100 Hours Since New

ENGINES

Pratt & Whitney PW206B2

#	TSN	S/N
ENG 1	2,100	PCE-BJ1199
ENG 2	2,100	PCE-BJ1203

HIGHLIGHTS

One Owner Since New

Single / Dual Pilot IFR

Dual EMS & PAX Interiors

All Logs in English

AVIONICS

Glass Cockpit

Single / Dual Pilot IFR GC GNS530WT/GNS430W

Digital Audio Control AMU50-003 & Control Unit ACP53 (NAT), Pilot & Co-Pilot Co-Pilot Flight Controls

Avionics/Master Radio Switches

Garmin GPS/NAV/COM GNS430W Pilot & Co-Pilot Interfaced w/FCDS

Goodrich 2" Standby Horizon (includes emergency battery A1804DC)

MEGHAS Dual (4xSMD45) Flight Control Display System (FCDS)

Avionics Pkg DP IFR GC GNS530WT / GNS430W Interconnection / Wiring Installation for Digital Audio Control System (DACS) ACP53 (NAT)

Honeywell KRA405B Radar Altimeter

MEGHAS Sensor Kit

Co-Pilot Static System

3-Axis digital Automatic Flight Control System (DAFCS)

Garmin Mode S GTX330 Transponder

Rockwell Collins DME4000 Dual Measuring Equipment

Iridium Satellite Communication & Tracking System

Fixed Provisions for Tactical Radio



FIXED PROVISIONS FOR FLIGHT DECK (SKY CONNECT)

Wiring for Digital Audio System (DACS) Control Unit ACP53 (NAT), Cabin

Traffic Advisory System TAS620 (Avidyne) includes interface to GNS430W/ GNS530WT (Garmin)

Video Radar Unit (VRU), Fixed Provisions

MARMS® Cockpit Voice & Flight Data Recorder, Fixed Provisions

EMS CONFIGURATION FEATURES/OPTIONS:

Medical Floor

Medical Equipment Carrier

Stretcher

Locker System Including Stretcher Ramp & Guide Locker System

Adapter Floor Cabinet

Medical Cabinet

Adapter Floor Oxygen Station

Oxygen Station

Adjustable Medical Crew Seat

Swiveling Medical Crew Seat

2013 Airbus EC135P2+ | #1107 | TC-HGA

Contact: Emmanuel Dupuy / +1 289 400 4725 / ed@aeroasset.com



TOTAL HOURS
2,100 Hours Since New

ENGINES

Pratt & Whitney PW206B2

#	TSN	S/N
ENG 1	2,100	PCE-BJ1199
ENG 2	2,100	PCE-BJ1203

HIGHLIGHTS

One Owner Since New

Single / Dual Pilot IFR

Dual EMS & PAX Interiors

All Logs in English

FEATURES/OPTIONS:

Voice Alert Generation for AMU53 (NAT)
FCDS / DAFCS GPS Selection Switch for Garmin GNS430W
HTAWS for Garmin GNS530WT
Kannad AF/AP ELT
Rotor Brake System
External Loudspeaker w/Siren, Fixed Provisions/Detachable Parts
7" Co-Pilot Instrument Panel with Glare Shield
Map Case (Co-Pilot Cockpit Door, on Instrument Panel Glare Shield) Illuminated Chart Holder (Pilot)
Bleed Air Heating w/Additional Air Outlets in Cargo Compartment Saft 40Ah, 24 VDC ULM Battery
Alternating Current System (50 VA)
Starter Generator (2x200 A, 28 VDC)
Reinforced Rear Landing Gear Cross Tube
External Rope-Down Device LH, Fixed Provisions
Separation Curtain for Cockpit, Fixed Provisions
Landing & Search Light (450W)
Multifunction Handle on Main Gearbox Cowling (LH&RH)
Cable Cutter System, Fixed Provisions
Fuzz Burners for Engines
Engine Fire Extinguishing System
Engine Outlet Heat Protection
Engine Compressor Wash Kit
Corrosion Protection for High Corrosive Environment
Flashlight for Co-Pilot Side



Tinted Sun Shades for Cockpit Windshield Roof Section
Windshield Wiper System
Slant Panel; Center Console
Additional Power Outlets (Center Console)
Honeywell Marker Beacon Receiver & Lights KR21
Active Noise Reduction (ANR), Fixed Provisions
Headset Adapter Cable GLENAIR/U92 for Cabin & Cockpit

INTERIOR:

This aircraft is delivered with two (2) interiors;

An Air Ambulance Technology EMS interior featuring one (1) stretcher adjacent to two (2) medical crew seating, one (1) seat is adjustable while the other medical crew seat swivels. Additional amenities include a medical equipment carrier, locker system, stretcher ramp and guide, oxygen station, medical/adaptor floors and medical cabinet.

A five (5) passenger VIP interior featuring seating for three (3) passengers facing the back opposite seating for two (2) forward facing passengers, seats feature a 3-point restraint system. Additional amenities include a Map Case in the LH/RH sliding doors.

EXTERIOR:

Red Upper, White Center and Lower Red with Black Accent on Nose.

2013 Airbus EC135P2+ | #1107 | TC-HGA

Contact: Emmanuel Dupuy / +1 289 400 4725 / ed@aeroasset.com





2013 Airbus EC135P2+ | #1107 | TC-HGA

Contact: Emmanuel Dupuy / +1 289 400 4725 / ed@aeroasset.com





2013 Airbus EC135P2+ | #1107 | TC-HGA

Contact: Emmanuel Dupuy / +1 289 400 4725 / ed@aeroasset.com





2013 Airbus EC135P2+ | #1107 | TC-HGA

Contact: Emmanuel Dupuy / +1 289 400 4725 / ed@aeroasset.com





2013 Airbus EC135P2+ | #1107 | TC-HGA

Contact: Emmanuel Dupuy / +1 289 400 4725 / ed@aeroasset.com





2013 Airbus EC135P2+ | #1107 | TC-HGA

Contact: Emmanuel Dupuy / +1 289 400 4725 / ed@aeroasset.com



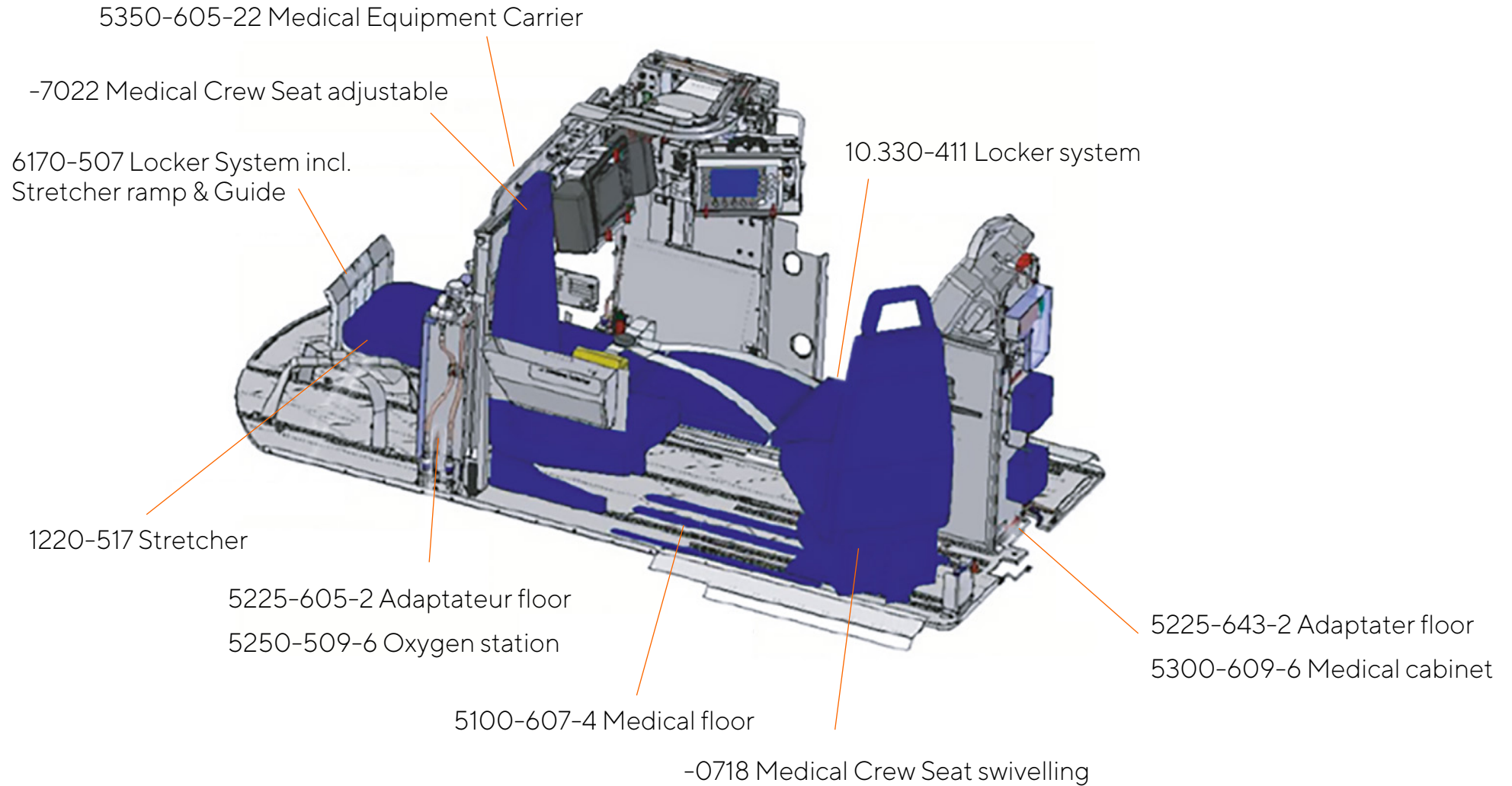

2013 Airbus EC135P2+ | #1107 | TC-HGA

Contact: Emmanuel Dupuy / +1 289 400 4725 / ed@aeroasset.com





2013 Airbus EC135P2+ | #1107 | TC-HGA

Contact: Emmanuel Dupuy / +1 289 400 4725 / ed@aeroasset.com





2013 Airbus EC135P2+ | #1107 | TC-HGA

Contact: Emmanuel Dupuy / +1 289 400 4725 / ed@aeroasset.com





2013 Airbus EC135P2+ | #1107 | TC-HGA

Contact: Emmanuel Dupuy / +1 289 400 4725 / ed@aeroasset.com





2013 Airbus EC135P2+ | #1107 | TC-HGA

Contact: Emmanuel Dupuy / +1 289 400 4725 / ed@aeroasset.com





2013 Airbus EC135P2+ | #1107 | TC-HGA

Contact: Emmanuel Dupuy / +1 289 400 4725 / ed@aeroasset.com





2013 Airbus EC135P2+ | #1107 | TC-HGA

Contact: Emmanuel Dupuy / +1 289 400 4725 / ed@aeroasset.com





WWW.AEROASSET.COM

Aero Asset / 181 Bay Street, Toronto, Canada M5J 2T9 / Phone: +1732 578 8217 / sales@aeroasset.com

